

Product data sheet

Characteristics

ILS1W853PB1F0

integrated drive ILS with stepper motor - 24..36V - pulse/direction 5V RS422- 5A

Product availability: Non-Stock - Not normally stocked in distribution facility

Price*: 1650.00 USD



Main

Range of product	Lexium integrated drive
Product or component type	Motion integrated drive
Device short name	ILS
Motor type	3-phase stepper motor
Number of motor poles	6
Phase	Single phase
[Us] rated supply voltage	36 V 24 V
Network type	DC
Communication interface	Pulse/Direction 5 V RS422, Integrated
Length	9.74 In (247.3 mm)
Winding type	Medium speed of rotation and medium torque
Electrical connection	Printed circuit board connector
Holding brake	With
Gear box type	Without
Nominal speed	120 rpm 36 V 60 rpm 24 V
Nominal torque	53.10 Lbf.In (6 N.m)
Holding torque	53.10 Lbf.In (6 N.m) holding brake 53.10 Lbf.In (6 N.m)

Complementary

Mounting support	Flange
Motor flange size	3.35 In (85 mm)
Number of motor stacks	3
Centring collar diameter	2.36 In (60 mm)
Centring collar depth	0.08 In (2 mm)
Number of mounting holes	4
Mounting holes diameter	0.26 In (6.5 mm)
Circle diameter of the mounting holes	3.90 In (99 mm)
Feedback type	Index pulse
Shaft end	Untapped

Second shaft	Without second shaft end
Shaft diameter	0.55 In (14 mm)
Shaft length	1.18 In (30 mm)
Supply voltage limits	18...40 V
Current consumption	5000 mA maximum continuous
Associated fuse rating	10 A
Input/output type	4 signals (each be used as input or output)
Voltage state 0 guaranteed	-3...4.5 V
Voltage state 1 guaranteed	15...30 V
Discrete input current	10 MA at 24 V safety input
Discrete output voltage	23...25 V
Maximum switching current	100 MA per output 200 MA total
Protection type	Overload of output voltage Short circuit of the output voltage Safe torque off
Peak stall torque	53.10 Lbf.In (6 N.m)
Continuous stall torque	53.10 Lbf.In (6 N.m)
Speed feedback resolution	1.8°, 0.9°, 0.72°, 0.36°, 0.18°, 0.09°, 0.072°, 0.036° 200, 400, 500, 1000, 2000, 4000, 5000, 10000 steps
Accuracy error	+/- 6 arc min
Rotor inertia	3.5 Kg.Cm ²
Maximum mechanical speed	1000 Rpm
Maximum radial force Fr	110 N
Maximum axial force Fa	170 N tensile force) 30 N force pressure)
Service life in hours	20000 H bearing
Brake pull-in power	22 W
Brake release time	40 Ms
Brake application time	20 Ms
Marking	CE
Type of cooling	Natural convection
Net weight	14.33 Lb(US) (6.5 kg)

Environment

Standards	IEC 60072-1 EN 61800-3:2001, second environment EN/IEC 61800-3 EN 61800-3 : 2001-02 EN 50347 IEC 61800-3, Ed 2 EN/IEC 50178
Product certifications	CUL TÜV UL
Ambient air temperature for operation	122...149 °F (50...65 °C) with power derating of 2 % per °C) 32...122 °F (0...50 °C) without derating)
Permissible ambient air temperature around the device	221 °F (105 °C) power amplifier 230 °F (110 °C) motor
Ambient air temperature for storage	-13...158 °F (-25...70 °C)
Operating altitude	<= 1000 m without derating
Relative humidity	15...85 % without condensation
Vibration resistance	20 m/s ² 10...500 Hz) 10 cycles EN/IEC 60068-2-6
Shock resistance	150 m/s ² 1000 shocks EN/IEC 60068-2-29
IP degree of protection	Shaft bushing IP41 EN/IEC 60034-5 Total except shaft bushing IP54 EN/IEC 60034-5

Ordering and shipping details

Category	18288 - LEXIUM INTEGRATED DRIVES II
Discount Schedule	PC56
GTIN	03389119227896
Nbr. of units in pkg.	1
Package weight(Lbs)	12.13 Lb(US) (5.5 kg)
Returnability	No
Country of origin	DE

Packing Units

Unit Type of Package 1	PCE
Package 1 Height	4.13 In (10.5 cm)
Package 1 width	7.48 In (19 cm)
Package 1 Length	15.35 In (39 cm)

Contractual warranty

Warranty	18 months
----------	-----------

Integrated Drive with Holding Brake

Dimensions

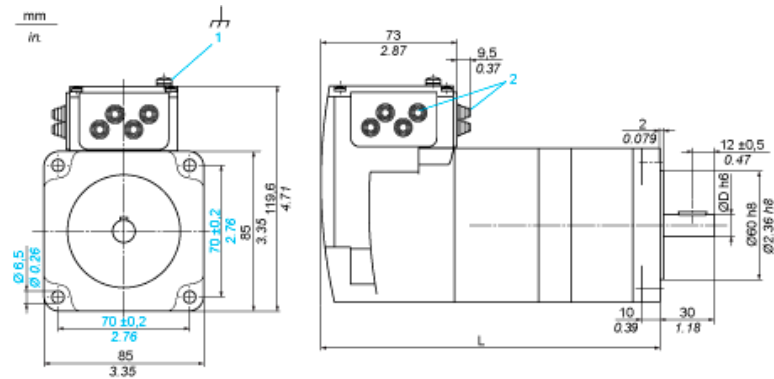

- 1 Earth (ground) terminal
- 2 Accessories: cable entries $\varnothing = 3 \dots 9 \text{ mm}/0.12 \dots 0.35 \text{ in.}$
- L 247.3 mm/9.74 in.
- D 14 mm/0.55 in.

Multifunction Interface

Input Wiring Diagram

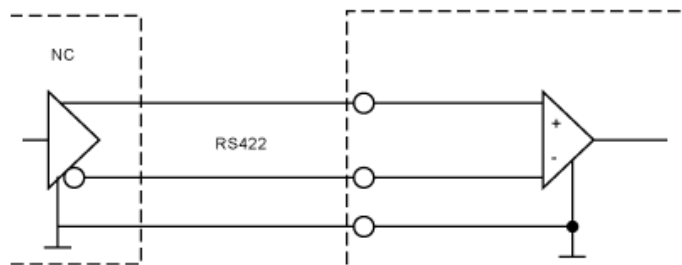

The reference pulses are supplied via two of the signal inputs, either as pulse/ direction signals or as A/B signals. The other signal inputs have the functions "power amplifier enable/pulse blocking" and "step size switching/PWM motor current control".

Torque Characteristics

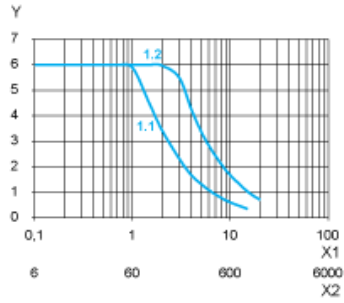

- X1 Frequency in kHz
- X2 Speed of rotation in rpm
- Y Torque in Nm
- 1.1 Max. torque at 24 V
- 1.2 Max. torque at 36 V

Product Life Status : **Commercialised**